



SPEC SHEET

SPS-08

MODEL

JOLIE



CATALOG SIZES

50

70

100

DESCRIPTION

Custom round mirror with outer sandblasted ring (50mm)

ASSEMBLY MATERIALS

ELECTRICAL MATERIALS

LED Strip	<i>LED IP44 SMD 120 dots/m 12v: - Bi-LED light (3000-6000K)</i>
Transformer	<i>Class II 220-240V 50Hz IP44</i>
Connection box	<i>IP44 2 poles</i>
Features	<i>Frontal IR sensor, demister, light dimmer</i>

NON ELECTRICAL MATERIALS

Frame	-
Back frame	<i>PVC strip</i>
Glass	<i>Mirror glass. 4mm. Polished edge</i>
Hangers	<i>Galvanized steel</i>
General adhesive	<i>Neutral silicon for glass</i>
LED adhesive	<i>Fast-drying adhesive</i>
Wall anchors	<i>Plugs+Hooks (2+2) not for drywall</i>
Protections	-
Instructions	<i>CLBN LED Mirror instructions</i>

PACKAGING

Interior protection	<i>Expanded PS slotted (35x40mm)</i>
Outer package	<i>Cardboard box Cardboard corner protectors (x4)</i>
ID label	<i>100x150 label (client / ref. / descrip.) 100x38 label (client / ref. / descrip.)</i>

CERTIFICATIONS

AIDIMME: 22003059 (SECURITY)

IMQ TECNOCREA: GENEX210101.00 (HARMONIZED)

DRAWING

Ø50

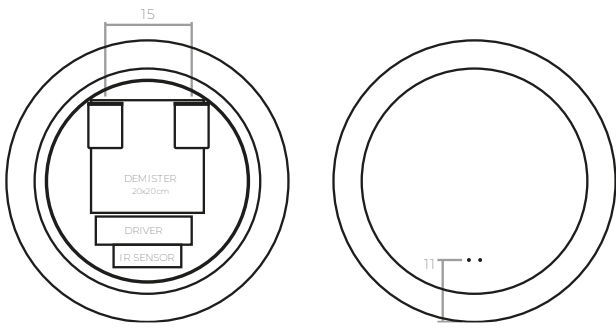

Ø70

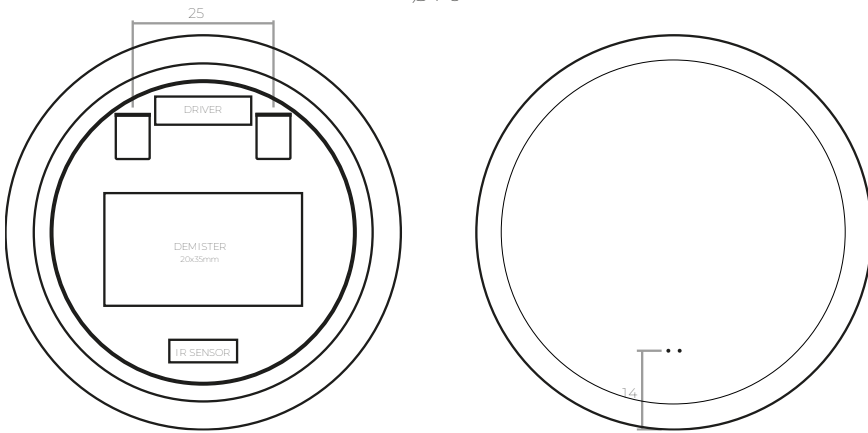

Ø100

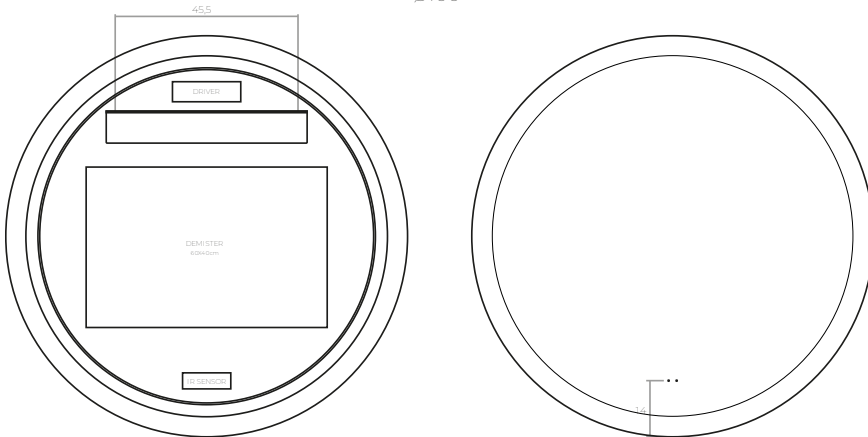

FEATURES



REF: AV

DEMISTER FILM. Heated film installed on the back of the mirror.

*Up to 120cm: 1 unit. From 120 to 150cm: 2 units. 160cm or more: 3 units.



FRONTAL INFRARED SENSOR. Acts to turn on/off LED and Demister, change Bi-LED ambient lighting and dim or increase light intensity.

OPTIONAL ELEMENTS

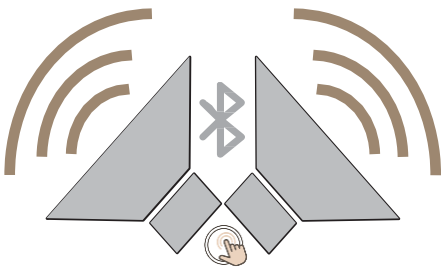

REF: BT

BLUETOOTH SPEAKERS. Pair of BT speakers installed on the back of the mirror.

*Touch sensor included.

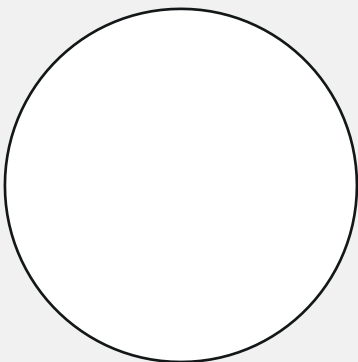

REF: AM

MAGNIFYING GLASS. 3x magnifying glass with a diameter of 12. Sticks magnetically to the surface of the mirror.

POWERS AND LUMENS

MIRROR

SIZE	POWER	LUMENS
50	16 W	1750 lm
70	22 W	2350 lm
100	25 W	3650 lm

OPTIONAL ELEMENTS

	POWER	LUMENS
DEMISTER		
40X40*	40	X
MAGNIFICATION	6	650
BT SPEAKERS	3	X

* The standard size of the demister film used by ID BATH AND SPA Ltd is 40x40cm. However, the size of the mirror or the placement of optional elements may affect its installation, requiring the use of panels with different dimensions.